

HELIOCOL

Swimming Pool Solar Heating System

Installation Manual



HELIOCOL SOLAR PTY LTD

24 Gassman Drive, Yatala Qld 4207

Phone: 1300 132 968 Fax: 07 3382 7915

www.heliocol.com.au

1	Introduction	3
	Overview	3
	Conventions used in this Guide	4
	Safety precautions	4
2	Basic Heliocol terminology	5
3	Designing your system	6
	Deciding on the location for the panels	6
	Preparing a schematic diagram	7
	Sample collector system	8
	Mounting racks.....	9
4	Parts and tools	10
	Heliocol fittings	11
	Pipes and other fittings.....	12
	Tools.....	13
5	Hydraulics	14
	Panel configurations	14
	Plumbing	16
	Balanced flow.....	16
	Pump power	17
	Automatic drainage.....	17
6	Installation.....	18
	Connecting panels together.....	18
	Bypassing a small obstruction.....	20
	Connecting panels across a large obstruction	20
	Fixing panels to a sloping roof	21
	Cementing PVC joints.....	25
7	Connecting to the existing equipment	26
	Feed and return lines	26
	Connecting with the existing filtration system	27
8	Troubleshooting	28
A	Site evaluation sheet.....	30
B	Replacing a damaged riser tube	32
C	Parts list.....	34
	Heliocol parts	34
	Standards & Certifications.....	35

1 Introduction

*Heliocol Solar Pool Panels are manufactured utilising state-of-the-art technology and production techniques. Heliocol collectors are sleek and simple, yet the **patented over-moulded design** makes them durable enough to last a lifetime. Correct installation is essential to the overall success of the system. Installed correctly, a Heliocol System is practically maintenance free, as it taps solar heat year after year.*

This manual contains easy, step-by-step instructions to help ensure that your installation meets our recommended standards. It also includes techniques and tips gathered from experienced Heliocol contractors that will save you time and effort.

Overview

Heliocol solar heating systems can be either mounted on a roof or on the ground. In either case the collectors may lie directly on the mounting surface, or, if a change of angle is necessary, on a specially constructed rack.



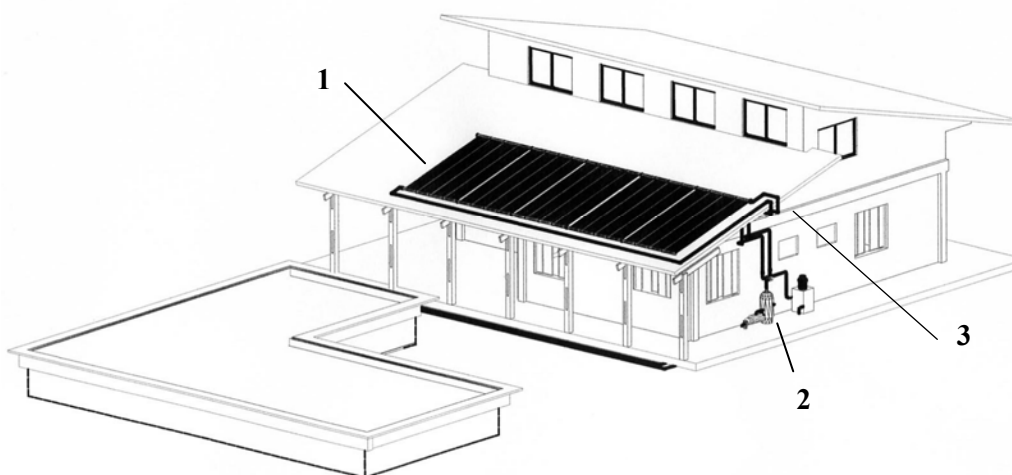

The illustration below is of a typical roof mounted system, highlighting the three basic areas:

1. The solar collectors
2. The existing water filtration system
3. The feed-and-return plumbing that connects between the solar panels and the existing filtration system.



Conventions used in this Guide

Table 1: Icons used in this Guide

Icon	Meaning
	Safety warning
	Important note
	General note
	Practical tip



Important: While this manual explains how to install Heliocol Solar Panels properly in typical situations, it cannot address all the possible individual cases. If you have any installation questions, contact your Heliocol representative for assistance. As the installing contractor, you are responsible for fulfilling top quality standards when installing Heliocol panels.

Safety precautions



Warning: There is no substitute for safety. Do not take short cuts. Always exercise extreme caution, care and good judgement when working on or around a roof or pool area.

- Take care to avoid hazards such as **overhead electrical wires** or **loose tiles**.
- Do not allow **extension cords** to trail into the pool or other stagnated water.
- Disconnect the **power supply** to the pool when installing an automatic control system.
- When working on a steep roof, use a **safety rope**.
- Be sure to **secure ladders** so they do not slip or fall.
- Wear shoes with good tread to **avoid slipping** on the ladder or sloping roof areas.
- **Do not leave materials or equipment on a sloping roof** where they could fall off.
- When working outdoors in warm weather keep yourself adequately **protected from the sun** and make sure to **drink regularly**.



Important: Avoid treading on Heliocol collectors! Wherever possible, the system should be installed so that all parts of it are accessible.

2 Basic Heliocol terminology

Modules /panels / banks/ arrays

Heliocol collectors are manufactured as individual “modules”, and connected together in the factory in groups of four modules to form “panels”. You connect the supplied panels together to form “banks” of various lengths, depending on the individual requirements at your site.

A Heliocol solar heating system consists of one or more banks of collectors, connected to the swimming pool filtration system.



Module – Modules come in a variety of four lengths, always 30cm wide.



Panel – 4 modules welded to one another at the factory.

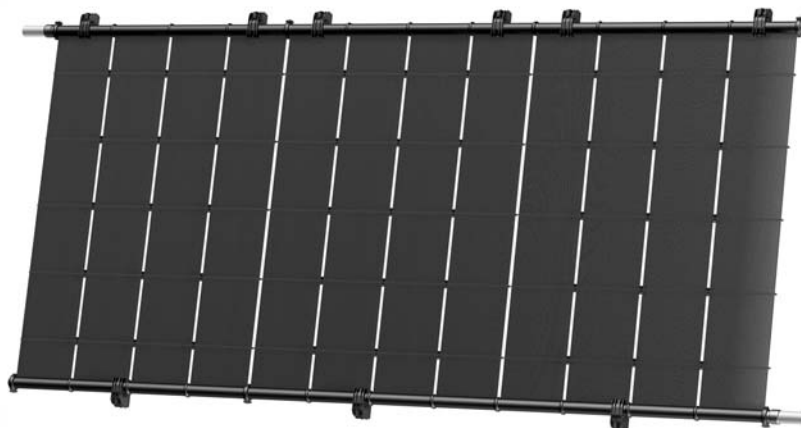

Bank – a structure made of several panels joint together with specific PPC connectors.

3 Designing your system

This chapter describes the factors you need to take into account when designing your system, and the process of creating the plan of the system structure.



Important: At all stages of the design and construction keep in mind that you want to produce a system for the customer that will be as efficient and as *aesthetically pleasing* as possible.

Deciding on the location for the panels

The first thing to do is determine the location of your solar heating system. The following factors must be taken into account:

- **Collector area** – The total panel area must be large enough to heat the pool efficiently. The exact optimum size depends on many factors in addition to the pool surface area, including pool depth, climate, latitude, roof orientation and slope, winds, pool covered at night and the presence of local obstructions (such as overhanging branches) between the panels and the sun.

An approximate “rule of thumb” is to allow for a collector area equal to the surface area of the pool.

- **Proximity to pool** – The panels need to be as close to the pool as possible, to reduce heat loss in the plumbing, and possibly the need for an additional pump.
- **Orientation** – Ideally the collectors should be mounted on a flat or north facing roof, or an elevated ground mounted rack, facing north. Where necessary, East facing or West facing roofs can be used (in that order of preference). If you have to mount collectors on a south facing slope, it is recommended to construct a reverse rack.
- **Tilt** – Be sure the planned position of the collector panels allows for them to drain naturally when the pool pump shuts off.



Tip: The “ideal” angle for maximum solar collection should be similar to the local latitude or up to 15° higher. However, any angle that allows for self-drainage of the panels is sufficient.



Important: Mounting the solar panels in certain locations, and/or constructing a support structures (if any) may require building permission. Consult with the appropriate authorities, or check with your local building department, about permit requirements and codes that may apply, before you start work.

Preparing a schematic diagram

Once you have decided on the location for the panels, prepare a schematic diagram of the system you wish to construct, taking into account the collectors sizes available.

1. Fill in the “Site evaluation sheet” in Appendix A. This will help you decide on the best system for your site.
2. Prepare a schematic drawing of the installation area. Include the proposed location of the feed and return lines.
3. Use the panel dimensions in the table below to sketch the system you will construct.



Tip: Roof areas often give the impression of being bigger than they really are, so be sure to actually *measure* the available area before making your drawing.



Note: Where possible construct your system using panels of the same length (if possible the largest length). Use individual *modules* only if essential.

Table 2: Module/panel area dimensions

Item	Width	Length	Area
Panel			
HC-30	120 cm	232 cm	2.77 m ²
HC-38	120 cm	292 cm	3.5 m ²
HC-40	120 cm	325 cm	3.85 m ²
HC-50	120 cm	385 cm	4.62 m ²
Module			
HC-8	30 cm	232 cm	0.7 m ²
HC-10	30 cm	292 cm	0.9 m ²
HC-10.5	30 cm	325 cm	0.98 m ²
HC-12.5	30 cm	232 cm	1.15 m ²

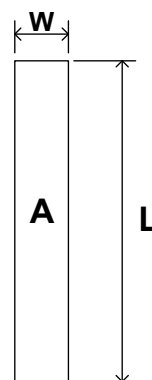
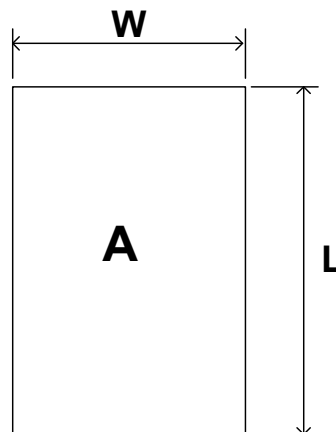

Sample collector system

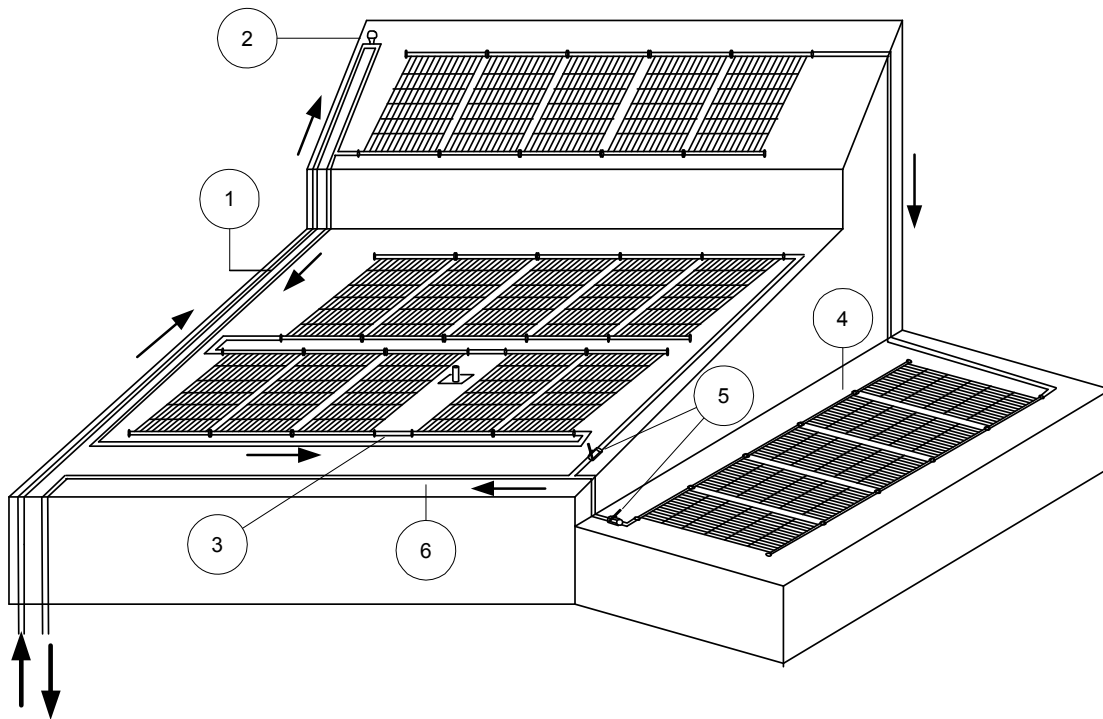

Figure 3.1: Sample collector system

1. Feed line climbing to the farthest point from pump house.
2. Air release valve at highest point (optional).
3. PVC pipe connecting across a large obstruction
4. Flat roof
5. Balance valves in the return line.
6. Return line as short as possible.



Note: Full details of how to connect the supply and return pipes are given in Chapter 7.

Mounting racks

Where there is no roof space, or not enough for all the collectors, you may need to construct a rack to mount some or all of the Heliocol panels. The rack must provide a *stable* base for the panels to be secured to.

When designing a mounting rack the following considerations should be taken into account:

- The tilt of the rack should be as near as possible to the latitude of the location, to provide optimum solar collection.
- The tilt of the rack must be sufficient to allow the collectors to drain naturally when the pool pump shuts off.
- When calculating the area for the rack, take into account that collectors expand and contract due to temperature changes under normal working conditions. Allow 5cm extra length per collector.
- Allow room on the rack for the supply and return plumbing and plumbing between collectors and banks.
- The mounting rack must be stable, and able to support the weight of the collectors when filled with water, which is up to 5kg/m^2 .



Figure 3.2: Sample mounting rack



Note: Whenever unglazed solar collectors are installed on a rack, a substrate should be mounted on the rack prior to mounting the panel. This eliminates heat loss and stress created by wind blowing on the back side of the rack.

4 Parts and tools

Once you know the layout of your solar collector system, and how many panels/ modules you require, this chapter will help you calculate which Sunwave and other fittings you will need to complete your installation.

This chapter deals with the following three categories:

- Sunwave fittings and accessories
- Other fittings
- Tools

Description	Cat. No	Picture	Dimensional Data
<p>PPC Set</p> <p>Plastic Panel Connector</p>	<p>120210 T/B PPC T&B</p> <p>120211locking clip</p> <p>4202100 rubber seal</p>		
C.P.V.C Adaptor	<p>420910 (2 inch)</p> <p>420910E (50 mm)</p>		
End Cap	120260		
Helio Roof Mounting Pad (Alligator)	120310		
A.R.I Vacuum breaker	<p>4201312</p> <p>4201315</p>		

Heliocol fittings and accessories

This section summarises the four basic types of connection to and between Heliocol panels, using Heliocol fittings.

Connecting between panels/modules

To connect a panel to a panel, or a panel to a module, you need a PPC connector set. This consists of a clamp top and bottom, a rubber gasket, and a latch.

When connecting two panels together you need two PPC sets (cat no. 120212), one to connect the upper manifolds and one to connect the lower manifolds.

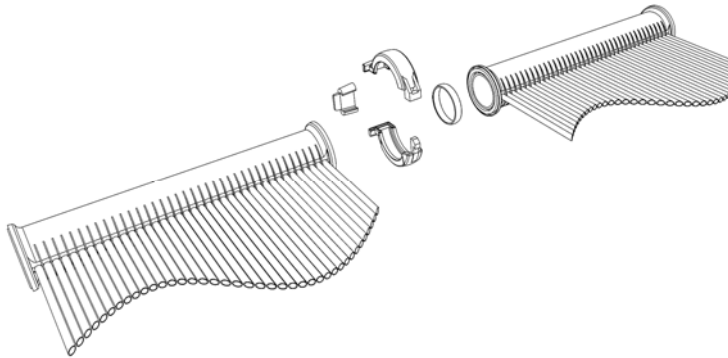
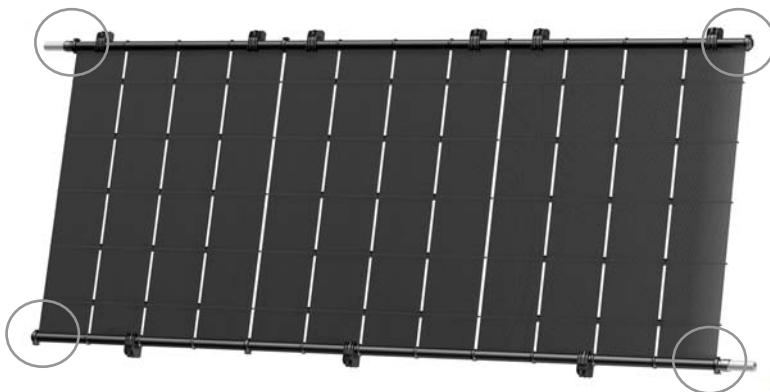

Figure 4.1: PPC (Plastic Panel Connector) set

Ends of a bank

When all the panels/modules in a row are connected together you will have four open ends. Two of these will be connected to the supply and return plumbing, and the other two will usually be blocked with end caps.



For each bank you will require:

**2 end caps (120260),
and**

2 CPVC adapters

Figure 4.2: Ends of a bank



Note: In some cases you might replace one of the end caps with an air release valve (4201312). See chapter 6 for more details.

Securing panels to the roof

Panels are secured to the roof using Heliocol mounting pads (Cat. 120320). In general allow 3 pads per panel, 2 at the upper end and one at the bottom. For steep roofs use 4 units per panel, 2 at the upper end and 2 at the lower end.

Heliocoll fittings summary

Table 3: Summary of Heliocoll fittings required

	Mounting Pads	PPC connectors	PVC adapters	End caps
For each panel	2-3	-	-	-
Between 2 panels	-	2	-	-
Between 2 panels across obstruction	-	4	2	-
For each bank ends	-	4	2	2

Pipes and other fittings

This section deals with pipes and other fittings you will need that are not supplied by Plastic Magen.

PVC pipe

Use only pressure rated Schedule 40/ PN16 PVC pipe.

! **Important:** As black PVC pipe is sometimes difficult to obtain, customers sometimes inquire about the use of black ABS pipe instead. **Do not use ABS pipe**, as it does not have the UV inhibitors that PVC pipe does, and hence does not withstand exposure to the sun nearly as well. After several years of exposure it may become brittle and crack.

PVC fittings

Use only pressure rated Schedule 40/ PN16 PVC fittings to match your PVC pipe.

! **Important:** Do not use “plumbers” fittings or DWV fittings (Drain, Waste and Vent).

! **Important:** If you cannot obtain black pipes & fittings, and wish to spray paint the fittings black, be sure to use high quality paint, preferably with UV inhibitors.

PVC cleaner and cement/ glue

Each PVC joint must be cleaned and glued with cement. Use a quality brand name product and follow the manufacturer’s directions for use on the product label.

Other fittings

Depending upon your specific job, you will need other plumbing items and materials such as: PVC valves, stainless steel lag bolts, silicone caulk, silicone spray, galvanised pipe straps, black electrical wire ties, electrical wire nuts, 18ga-22ga sensor wire, 14ga-16ga electrical wire with ground, Teflon tape, concrete anchors and screws, electrical conduit, etc. Be sure to use quality products that will withstand direct sun radiation for many years.

Additional parts you may need include:

- Vacuum breaker(s) (Recommended and supplied by Plastic Magen Cat. 4201311)
- Check valve
- Ball valve
- T-joint
- L-joint
- 3-way valve/ Automatic control
- Pipe reductions, bushings, sockets

Tools

Standard tools and materials that are useful to have when installing a Heliocol system are:

- Basic toolbox
- Chalk
- String
- Electric wire (to connect to automatic control)
- Coax (for sensor)
- Measuring tape
- Flat head and Phillips head screwdrivers
- Channel lock pliers
- Power drill with bits
- Caulking gun
- Pipe cutter or hacksaw
- Ladder
- Garden hose
- Hand saw
- Chisel

4 Hydraulics

This chapter deals with the hydraulics that need to be considered before installation.

Panel configurations

Before you can start constructing the system you have designed, you must consider how the banks will be connected together. You must also take into account the maximum number of panels allowed per bank, as shown below.

Table 4: Maximum number of panels allowed per bank

Panel type	Max. bank size
HC-30 (4'x8') Cat. 127108	12
HC-38 (4'x9.5') Cat. 127110	10
HC-40 (4'x10.5') Cat. 127111	10
HC-50 (4'x12.5') Cat. 127112	8

These maximums may be exceeded if there is high-pressure flow or substantial back pressure on the system that will force adequate flow through every panel. In other cases you should divide the bank into two using one of the other configurations.

Banks in parallel can also be used for smaller installations, when space is limited.

Basic plumbing & arrays layouts

SINGLE BANK

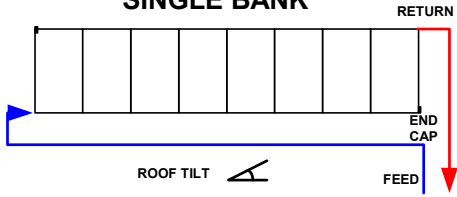

BANKS IN PARALLEL

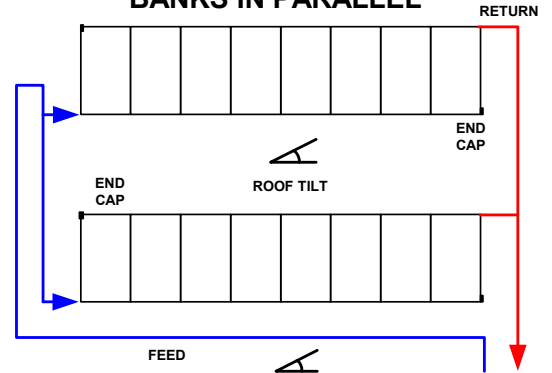

BANKS IN SERIES

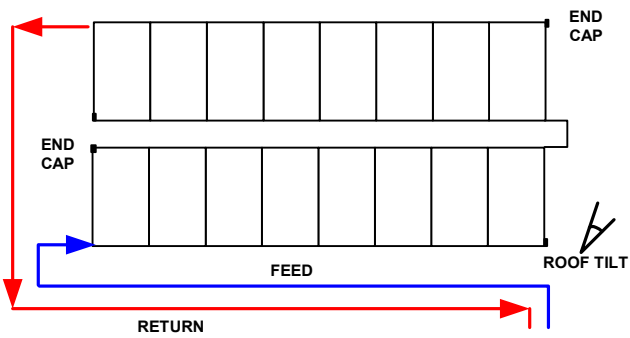

BANKS IN SERIES

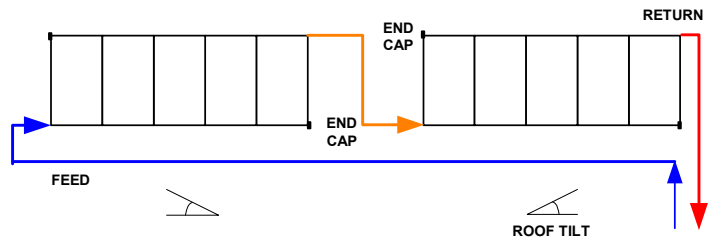

SINGLE BANK SPLIT FEED

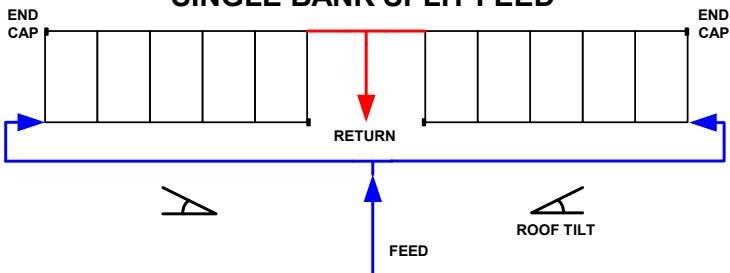

Plumbing

Water inlet /outlet

- Inlets are always connected to a lower end of the bank; outlets to the upper corner diagonally opposite.
- It is best to connect the inlet to the corner farthest from the pool, so that the outlet can be as near the pool as possible, to reduce heat loss.
- Using the “Reverse return” (Tichelmann) method would ensure balanced flow in all collector banks.

Pipe diameter

It is important that all plumbing connected to the system uses a diameter of PVC pipe appropriate to the size of your solar array. Too narrow a pipe will unnecessarily restrict water flow to the panels. Use the following as a guide:

Table 5: Recommended pipe diameters

Flow Rate	Recommended diameter	pipe
0-10 m ³ /h	40 mm (1.5")	
10-18 m ³ /h	50 mm (2")	
>18 m ³ /h	63 mm (2.5")	

For larger flow rates you may need to operate alternative series-plumbing techniques.

Plumbing runs

- Plumbing runs should be as short as possible, especially the “Hot Return” pipe (to minimise heat loss).
- Pipes should be supported every meter or so, to prevent sagging and movement.



Tip: Since 90° elbow fittings greatly restrict water flow, use as few of these as possible. In some cases two 45° fittings can be used in place of a 90° fitting.



Tip: When clamping pipes that run across the roof use clamps that allow 1cm for expansion of the pipe in hot weather.



Tip: When clamping pipes on the side of a building use clamps with a diameter equal to the pipe diameter, to prevent vibration and to assure a professional looking installation.

Balanced flow

If you install a split system, such as one of those shown in former page, it is essential that the piping is connected exactly as shown, to ensure equal water flow through both banks of panels. Water follows the path of least resistance, so if one plumbing run is shorter, more water will flow through it than through the longer one. This should also be kept in mind when designing a panel layout different to those shown.

For larger, more complicated configurations “balancing valves” may be necessary to maintain equal water pressure in all parts of the system.

Pump power

The horsepower of the swimming pool filtration pump must be adequate to supply the Heliocol system with enough water to provide the recommended flow rate necessary for the panels being installed. These recommended rates in litres per minute are:

Table 6: Recommended flow rate through the panels

Panel type	Minimum Flow	
HC-30	720	lit/hr
HC-38	900	lit/hr
HC-40	900	lit/hr
HC-50	1200	lit/hr

For example: If you were installing ten HC-40 (4'x10.5') panels, your pump would have to be able to deliver 9000 litres/hr to the solar array. These recommended flow rates may be exceeded by as much as 100% without any detrimental impact on the performance of the system. The existing pool filtration pump is usually adequate for circulating the water through the solar system.

Generally, a 1 horsepower pump is sufficient for a standard private pool solar system, unless there is an unusually long pipe run, a high roof, or a large number of panels. If you are not sure what your pump flow rate is, consult your Heliocol Representative or Pump Manufacturer for the pump's flow characteristics.

Automatic drainage

The panels and the PVC pipe must be installed so that the water drains out of them when the pool pump shuts off. This is especially important in areas where freezing occurs.

To allow for drainage a vacuum breaker is installed on the solar feed line above the 3- way valve, as shown in the draw on page 31.



Important: Heliocol Solar Pool Panels are warranted against internal freezing on condition that they are installed to allow for automatic draining.

Compensating for lack of automatic drainage

If, due to unusual roof design or pool equipment location, it is not possible to achieve complete automatic drainage, manual drain down valves must be installed in appropriate places in the plumbing, or at the end of the bottom (feed) header.

Instead of installing an End Cap at the end of the header, place a Vac Cap (120252) along with a ball valve for manual drain. These valves should be opened when shutting down the system for the winter months or when outdoor temperatures approach freezing point.

5 Installation

This chapter describes four basic installation processes:

- Connecting panels together
- Connecting panels across an obstruction
- Securing panels to the roof (sloping or flat)
- Gluing PVC joints



Tip: It is highly recommended to visit the site *before* installation day. Looking around the site after you have planned the installation layout is of great help in foreseeing and solving possible problems.

Connecting panels together

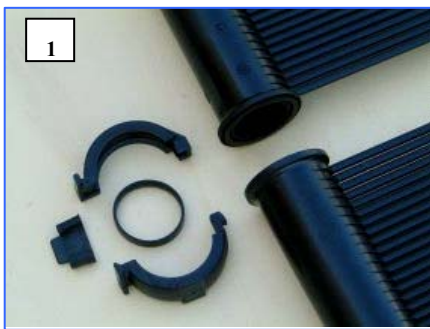

1

Lay the two panels side by side with the panel spacer bars facing down. Place a PPC connector (top, bottom, gasket and latch) at both ends where the headers meet



2

Clean the groove of both headers and dry them.



3

Insert the gasket (420211) into the groove of one of the headers.



4 Connect the two headers by inserting the rubber gasket (420211) into the opposite header groove and fitting the ends of both headers into the plastic panel clamp.



Important: Make sure that the gasket sits snugly in the grooves of both headers, and is not squashed or pinched between the headers, as this could result in leaks.



5

Place the bottom half of the plastic panel clamp under the header end with the larger, flat portion facing *away* from the panel.

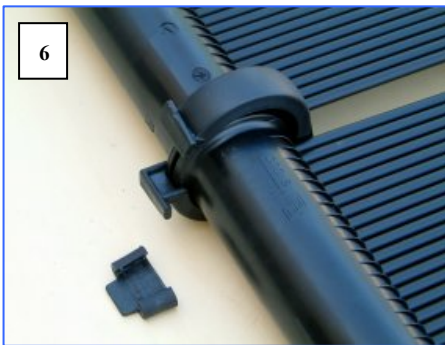

6

Interlock the tab in the top half of the clamp with the hole in the bottom half (120210B), swing the top half (120210T) round over the headers, then lock the two halves of the clamp together using the latch (do this by sliding the large end of latch over small end of the PPC assembly.)



7+8 Use channel lock pliers to tighten the latch grip by squeezing it with moderate force until it seats flush so it cannot slide out of its position.



9

The headers are now connected.

10

Repeat the procedure to connect the headers at the end of the panels.

Bypassing a small obstruction

Small obstructions can sometimes be bypassed simply by unclipping some risers from the spacer bars and spreading them to either side of the obstruction.

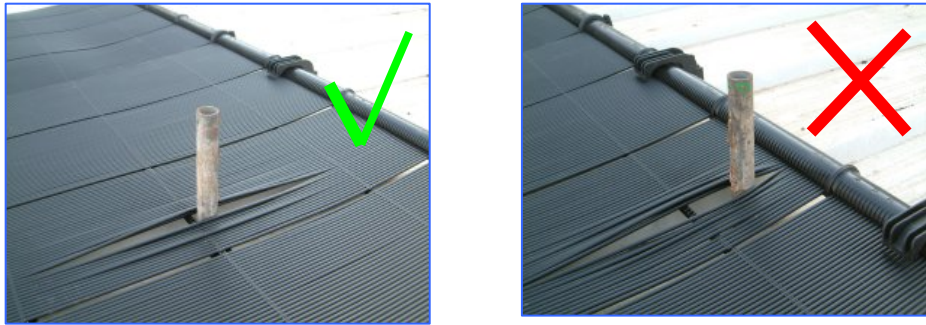

Figure 6.1: Bypassing a small obstruction



Important: If the obstruction is between one of the headers and the adjacent spacer bar this method must not be used, as it might cause a riser to become detached from the header. The Plastic Magen Warranty does not cover incorrect installation of this type.

Connecting across a large obstruction

For obstructions more than 15cm wide, or less than 30cm from one of the headers, you need to circumvent the obstacle using extension pipes between the manifolds.

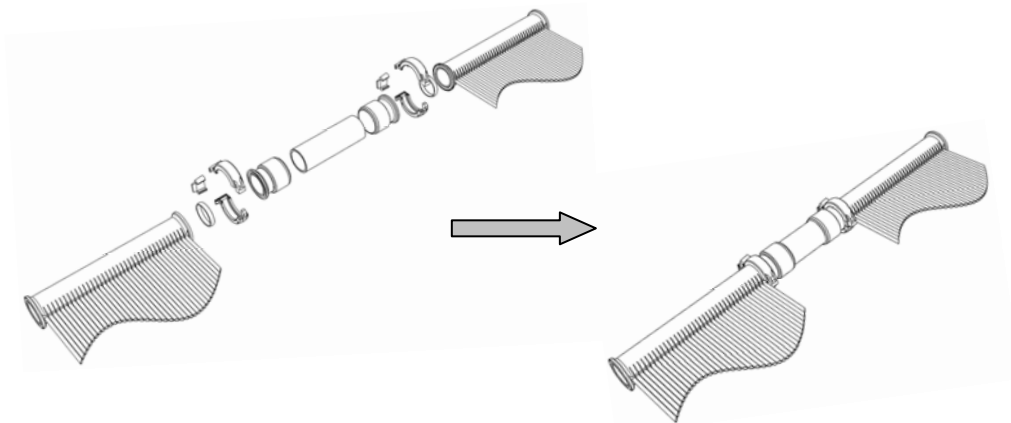

Figure 6.2: Connecting across an obstruction

Therefore, when connecting two panels/modules together across a large obstacle you need:

- 4 PPC sets
- 4 CPVC adaptors
- 2 lengths of PVC pipe cut to the required length.

Fixing panels to a sloping roof

Heliocol mounting pads (“Alligators”) are used to secure panels to the roof or rack. The following considerations apply:

- Mounting pad 120320 can be fitted to the panel anywhere along the manifold header, except within 5cm of the ridges where two modules join (to allow for thermal expansion).
1. In general, allow two mounting pads on the upper header of each panel, and one for the lower header. (On roofs with a pitch greater than 10/12 you need more pads, and on flat installations you can use less.)
 2. It is recommended to lock the centre of each bank in place, so as to spread thermal expansion and contraction evenly between both sides. To lock the centre panel of a bank, position the mounting pads on that panel adjacent to the left and right of *one* of the header ribs. These clamps should be attached using *two* lag bolts as opposed to one.
 3. In a strong inclination roof it is recommended to fix one mounting clamp at the lower manifold, to support the panel and to avoid it from lifting due to strong winds.
- For barrel tile roofs, each mounting pad needs to be positioned so that it is centred on the upper ridge of a tile.



Important: Never “lock” more than one position on a bank, as this could result in damage to the system due to thermal expansion and contraction.

To mount panels with Heliocol "Alligator" mounting pad:



1 Draw a chalk line across the roof or rack indicating where you want the top edge of the collectors to be located.

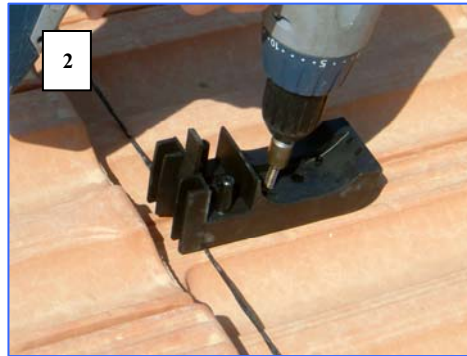

2 Position the first "Alligator" on the chalk line, about 15 cm from the top corner of the first



Note: Since the panels should slope slightly down toward the feed end of the array, for proper drainage, the chalk line should also slope down in this direction, approximately 2cm per 5m.



3 Subsequent "Alligator" should be spaced out evenly along the chalk line, approximately every 60 cm (for roofs with a pitch up to 40°). Apply sealant generously to the lower hole on the bottom half of the clamp.



4 Position the bottom half of the mounting clamp perpendicular to the chalk line, on the highest part of the tile.

5



5 Lag the clamp to the roof, through the lower hole. For barrel tile roofs, place a rubber pad (420320) underneath each clamp, by inserting the four feet of the rubber pad into the four corners of the bottom of the clamp, before lagging to the roof.



Tip: To ensure correct spacing of the clamps, hang the upper headers of panels in the lower halves of the clamps that have been attached to the roof, as you go.



Tip: The bottom of the clip is designed to grip the roof's surface to avoid twisting; however, if the roof surface is particularly hard or slippery you can use an additional lag bolt in either the top or lower hole.

Once all “Alligators” are properly lagged to the rack or roof surface, and all the collectors are hung in place, join the upper headers together with PPC connectors.



6 Snap the top portion of each mounting clamp over the panel header and onto the bottom portion of each clamp, pushing down firmly.



7 Attach “Alligator” mounting clamps to the lower headers, allowing one clamp per panel.



8 Ensure that all four corners of the bank are securely fastened to the roof.

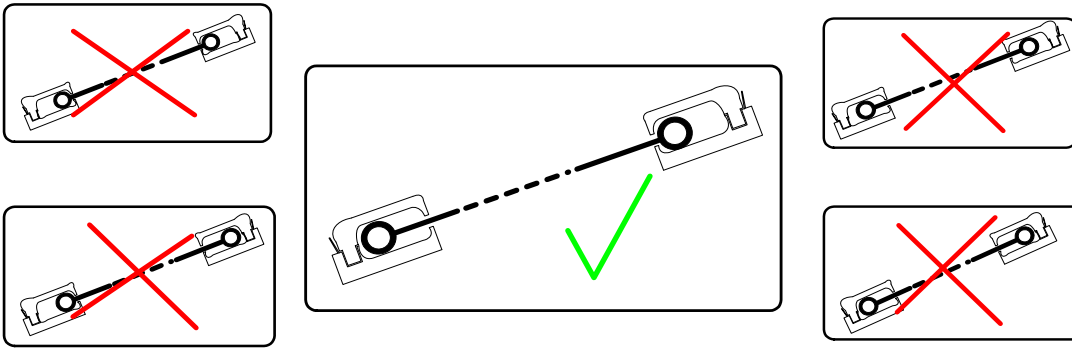

Fig 6.4: Correct installation of Heliocol mounting pad



Important: When fixing clamps to the lower headers, let the panel “hang down” in the upper mounting clamp, and then push the lower clamp up as far as it will go. Fastening the clamp in this position allows for thermal expansion and contraction.



Make sure that the Alligator mounting clamp is not installed over the welded joint between the modules.

Such an installation can “lock” the panels to the roof and a thermal distortion can occur



In a roof with pitch higher than 30° or in a high speed winds zones it is recommended to reinforce the alligator lock with two screws drilled to the back side of it.

(The alligator is produced with two special holes exactly for those occasions).



Tip: If you are installing the system on an inexpensive or soft asphalt shingle roof, it would be advisable to put some pads of aluminium roof flashing under the clamps holding the bottom headers, to prevent roof wear. The pads can be attached to the roof using silicone or other adhesive.

Cementing PVC joints



Important: When gluing PVC fittings to PVC pipe, such as the Heliocol Pipe Connector, be sure to use good quality PVC cement.



1 Before applying the cement, be sure to clean the contact areas with the PVC cleaner or “primer”.



2 Immediately after cleaning, apply cement first to the fitting and then to the pipe end. Immediately after cleaning, apply ample cement first to the fitting and then to the pipe end.



3 Insert the pipe end into the fitting with a slight twisting motion so as to spread the glue evenly, and seal the joint.

4 Hold it in position for 5–10 seconds to allow the cement to set slightly. Wipe away any excess cement.



Tip: By taping the cans of PVC cleaner and PVC Cement together you can reduce the risk of them tipping over and spilling.

6 Connecting to the existing equipment

This chapter describes the standard (and most common) method of running the PVC pipe from the feed and return lines to existing ground level equipment. Some installations may require a more creative approach.

Whenever possible, the return line should have the shortest run and all pipes should run slightly “downhill” to allow for automatic drain-down of the plumbing and solar array. If this is not possible, manual drain valves must be installed as needed.



Note: If the existing pool machine room is near the house, you may prefer to complete the necessary plumbing there before connecting between roof and ground level. That way you will know exactly where the pipes should come down from the roof. However, if you will be trenching from the existing equipment to the Heliocol installation location this is not necessary.

Feed and return lines

Feed and return lines are connected using a PPC connector and a CPVC adaptor. The remaining two open corners of the bank are sealed using PPC connectors and end caps.

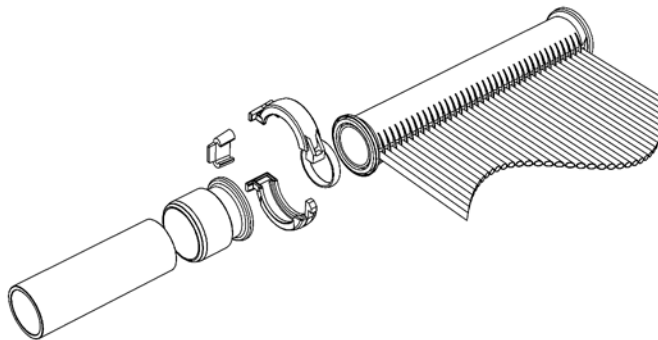
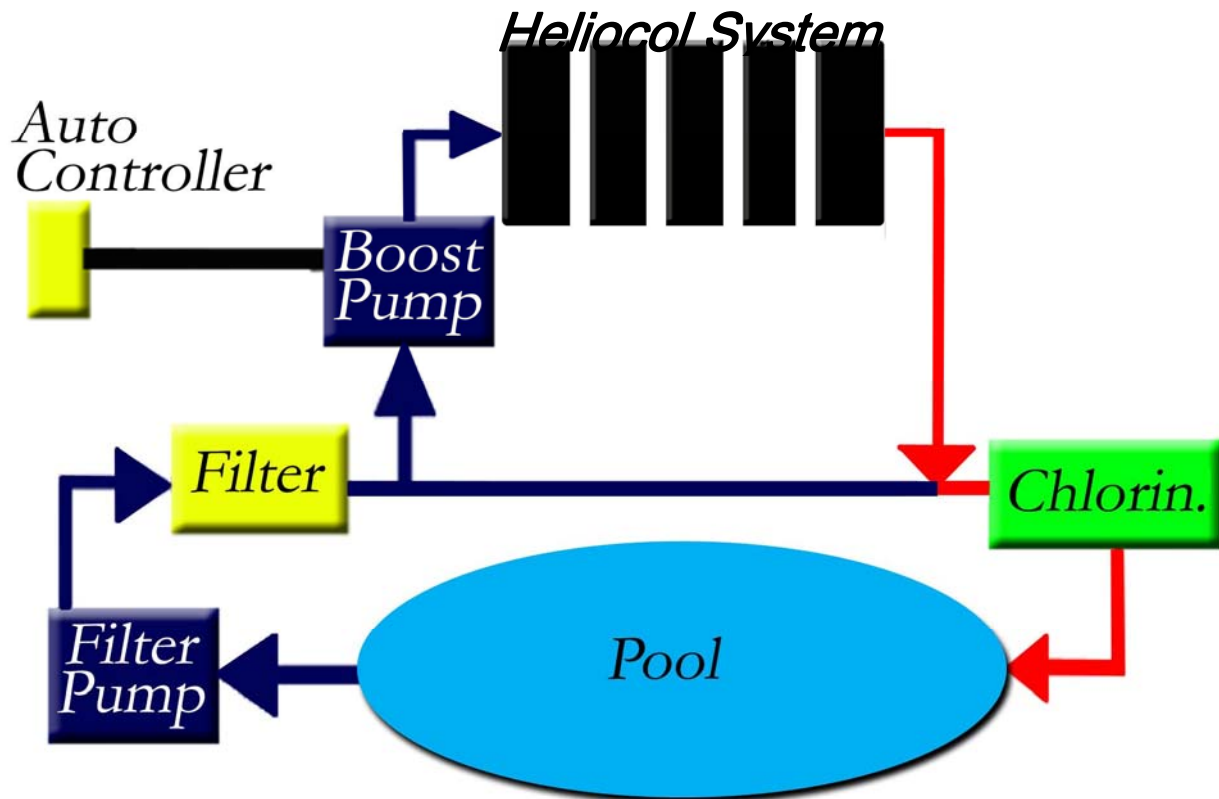

Fig 7.1: Connecting plumbing line to the collector

To connect the feed and return lines:

1. Connect the feed line to the low end of the bottom header, which should be the corner farthest from the pool pump, using a PPC connector and a CPVC adaptor.
2. Connect the return line to the top header on the opposite end of the bank. This gives the heated pool water the shortest route back to the pool.
3. Block the remaining two corners of the bank using **end caps** attached with PPC connectors.
4. Connect the feed and return pipes using reliable plumbing techniques.

Connecting with the existing filtration system



The figure above shows how a typical Heliocol Solar Pool Heating System is plumbed into existing pool plumbing. Even if your system is not identical to the one shown, the illustration can help you understand the flow of water from the pool, through the pump, filter, solar system and back to the pool.

8 Troubleshooting

This troubleshooting section will help you identify and solve any problems as quickly as possible.

There are air bubbles in the pool when the solar heater is operating

Diagnosis #1: There may be air coming into the pump through an air leak on the suction side of the pump due to the pump working harder to move the water through the solar system.

Pump Answers:

1. Check that the pump trap lid is secured tightly.
2. Check the “O” ring on the pump trap lid. Clean, lubricate or replace as needed.
3. If you have a suction type pool cleaner, remove it. If this eliminates the air bubbles, use it only when the solar system is off.
4. If the pump has a clear lid and you can see air bubbles in the trap, use a garden hose to run water over the lid, and each joint individually, to see if the air bubbles will clear up. If the lid is opaque, listen to pump noise to check that it is operating smoothly. Repair any air leaks.

Diagnosis #2: If the vacuum breaker is installed on the roof, there may not be enough water pressure in the system to keep the vacuum relief valve closed, so air could be drawn into the water as it flows through the valve.

Install Answers:

1. Check that the filter is clean. Backwash to reduce pressure.
2. Locate the vacuum breaker on the feed line and put a solid end cap at the end of the upper header where the vacuum relief was located.
3. Using the ball valve on the return line, throttle back the flow to produce more back pressure on the system.

Some of the solar panels are warm to the touch while others are cool

Diagnosis: There is not equal flow through all of the panels. Warm panels indicate low water flow.

Pump Answers:

1. Check that the filter is clean. Backwash to reduce pressure.
2. The pump may not be providing enough water to the solar system. Check water flow using a flow meter. Increase pumps horsepower to maintain recommended flow.
3. If there is a suction type cleaner in the pool, disconnect it. If this eliminates the problem, use it only when the solar system is off.

Install Answers:

1. If the system is a single row array and there is adequate flow, use the {HC-5210} Ball Valve on the return line to throttle the flow back to increase back pressure on the system. This will even out the flow through the panels. If the array contains more panels than the maximum recommended on Page 9 of this manual, change the array to a double row or single row split feed as shown in Fig 4.2 and 4.3.
2. If the system is a double row or a single row split feed array and there is adequate flow, install a Ball Valve on the return side of the set of panels that are the coolest to throttle back the flow through these panels and force more water through the warmer panels. If any section of the array contains more panels than the maximum recommended on Page 9 of this manual, make changes as needed to correct this.

Water coming from the system is not as warm as it should be

Diagnosis #1: The water is flowing too fast through the panels

Install Answer:

- Test water flow rate. Water flow through a single panel should be less than 2500 litres per hour. Adjust the Three-Way Valve to by-pass some of the water.

Diagnosis #2: Seasonal normal operation

Answer:

- In the cooler months of the year, or on cool or partly cloudy days, the temperature rise through the panels may only be 2° or 3° C. Use the back of your hand to feel the water temperature difference at the pool return inlet.

A Site evaluation sheet

Client contact info

Client Name:	
Tel:	Mobile:
Fax:	Date:
Address:	

Site info

Pool length (m)	Width:	Surface area:
Is pool covered at night? Y / N		
Is pool directly exposed to sunlight? Y / N		
When is pool used? All year round / Summer only		
Evaluated ideal collector area? (m ²):		
Diameter of supply and return pipes to be used (mm):		
Distance from collectors to pump (m):		
Roof height? (m)		
Current pump:		
Does pump need to be replaced? Y / N		
Specifications for new pump (if required):		
Supply:	Pressure:	Capacity:
Roof area available <i>and suitable</i> for collector installation (m ²):		
Roof orientation:	Roof tilt (degrees):	
Roof type: Tiles / Cement / Wood / Other (please specify):		
Special considerations:		

Basic system layout

Using the grid below to sketch the layout of your system will help you plan the best system, and work out exactly what Heliocol parts and extra PVC piping you need.

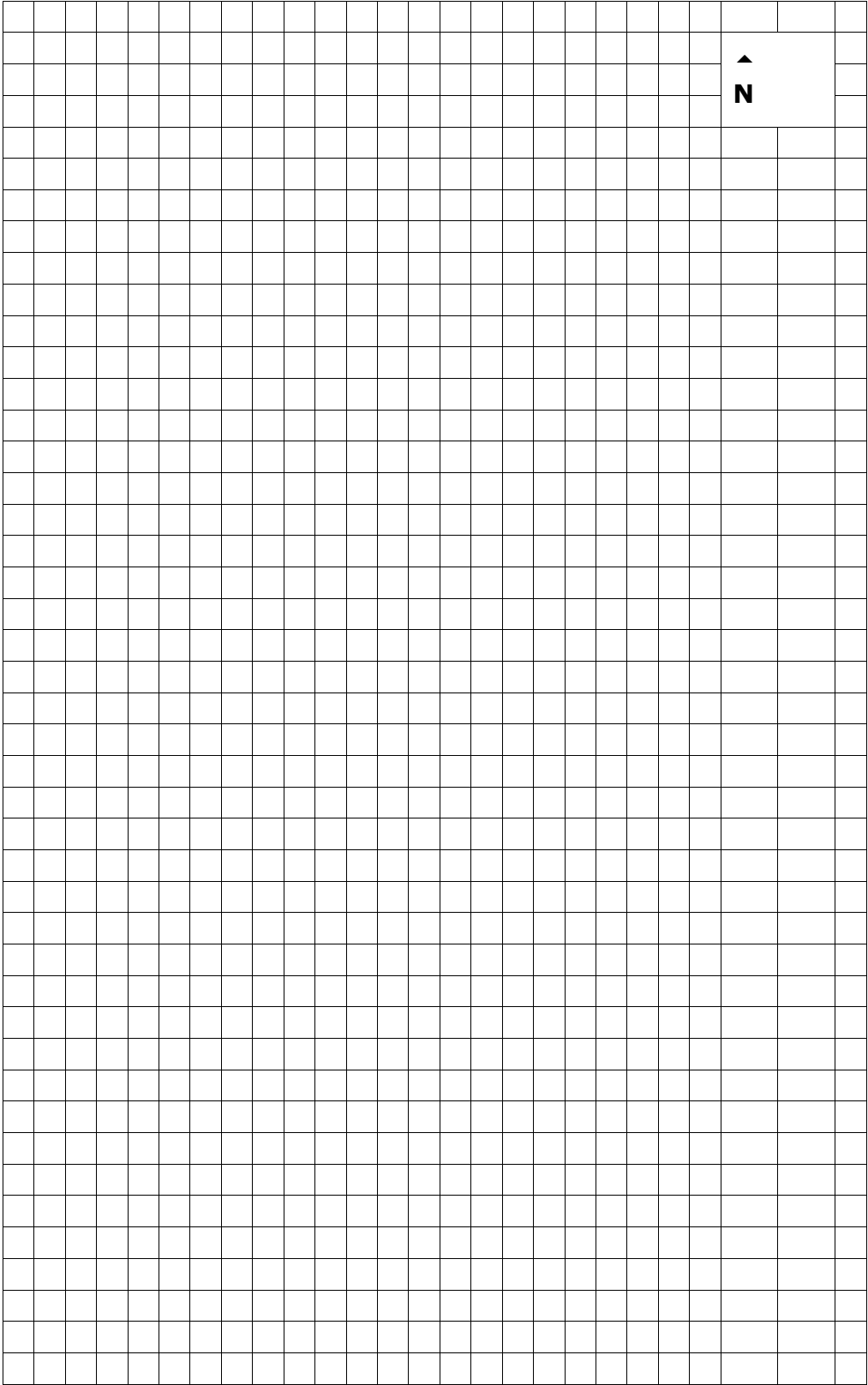

B Replacing a damaged riser tube

In the event of a riser getting damaged and leaking, one of the advantages of Heliocol collectors is the ease with which the leaking riser can be removed, the leak repaired, and a replacement riser attached to maintain the uniform appearance of the panel.

A damaged riser is replaced using a Heliocol riser repair kit (consisting of two rubber sleeves and two plastic plugs), and the broken riser itself.



Note: Water does not run through the replacement riser. The purpose of the replacement is only to maintain the uniform appearance of the panel.

Figure B1: Heliocol riser repair plug (left) and sleeve (right)

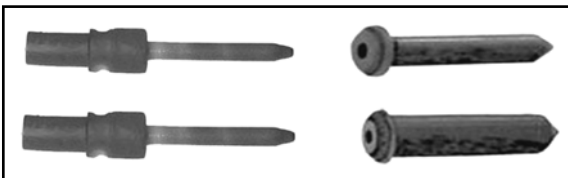

Cat. No.1202910 for panel **with** header

Cat. No.1203910 for panel **without**

Figure B2: Heliocol riser repair tools:



Specific Heliocol repair handle

Cat. No. 1202880

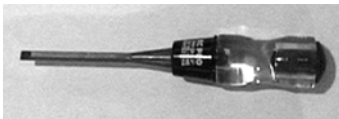

7 mm Chisel



Important: Do not use a chisel more than 7mm wide, as you might damage the adjacent risers as you remove the broken riser.

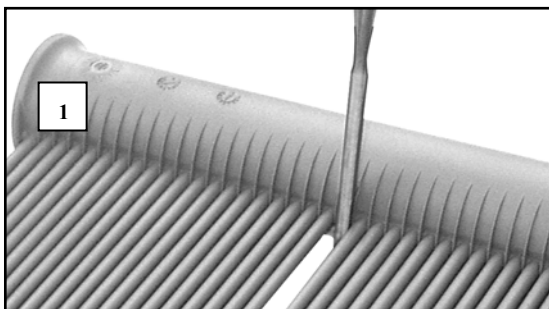

1 Using a 7mm chisel, and holding the flat side of the chisel towards the header, cut through the damaged riser, flush against the header: A round hole is create in the manifold header.

Repeat at the other end of the riser and save the removed riser for use in the repair.

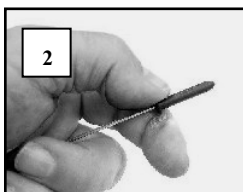

2 Spray the rubber sleeve with silicon spray and pull it over the small metal pin of the Heliocol repair handle.

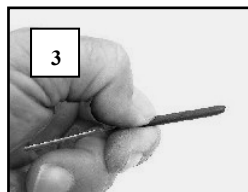

3 Stretch and relax the rubber sleeve couple of times over the metal pin.

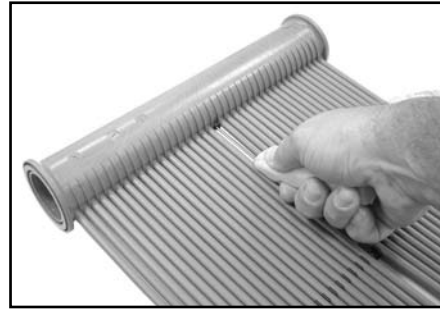
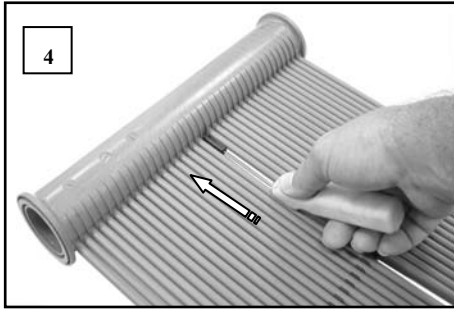

4 Using the repair handle gently push the rubber sleeve into one of the holes created by the removal of the riser, until only the head is showing.

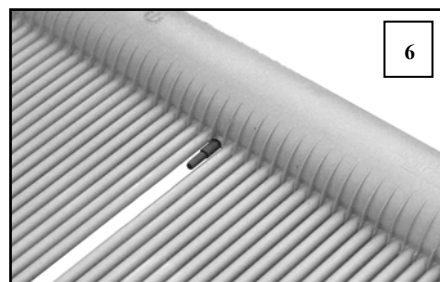
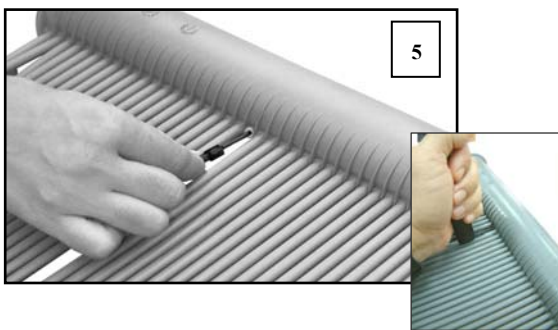

5 Push a plastic repair plug all the way down into the repair sleeve. You may use the rare part of the handle to do push it firmly into the sleeve.

6 The hole is plugged and will not leak.

Repeat steps 4 and 5 for the hole in the header at the other end of the panel.

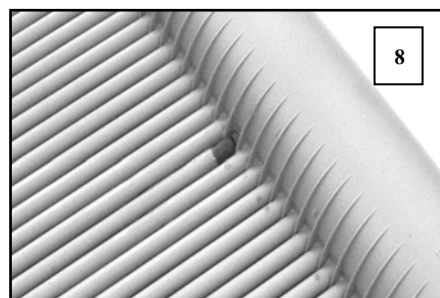
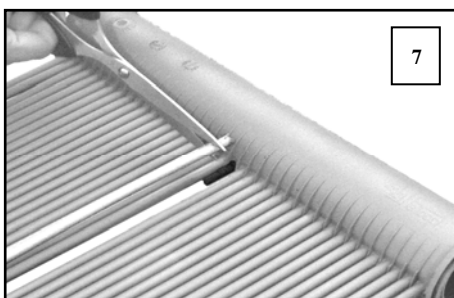

7 Cut the removed riser so it fits exactly between the broad heads of the plastic pins.







8 Fit the riser onto the stubs of the two repair plugs.

The panel is now leak free while its uniform appearance is restored.

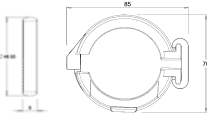
C Parts list

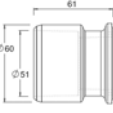
The following sections illustrate the Heliocol and other parts needed for a typical installation, to help you compile your own order.

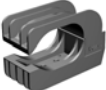
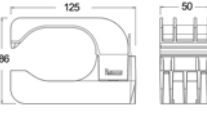
Heliocol parts

Description	Cat. no	Picture	Dimensional Data
<p>PPC Set</p> <p>Plastic Panel Connector</p>	<p>120210 T/B PPC T&B</p> <p>120211locking clip</p> <p>4202100 rubber seal</p>		
C.P.V.C Adaptor	<p>420910 (2 inch)</p> <p>420910E (50 mm)</p>		
End Cap	120260		
Helio Roof Mounting Pad (Alligator)	120310		
A.R.I Vacuum breaker	<p>4201312</p> <p>4201315</p>		

Standards & Certifications



--	--